

**REAL TIME AUTOMATION**  
150 S. Sunny Slope Rd. Suite 130  
Brookfield, WI 53005  
262-439-4999 (V)  
262-439-4989 (F)  
[www.rtaautomation.com](http://www.rtaautomation.com)

**RAW TCP CONTROLLOGIX<sup>®</sup> ETHERNET  
GATEWAY  
Catalog #490NBA**

Copyright ©2009 Real Time Automation

**DEFAULT IP ADDRESS 192.168.0.100**

ControlLogix is a Registered Trademark of Rockwell Automation

## TABLE OF CONTENTS

INTRODUCTION.....	3
Product Overview .....	3
Specifications .....	4
Contents of this Manual.....	4
CONNECTING TO YOUR RAW TCP DEVICE(S).....	5
Overview.....	5
Your TCP Device Requirements.....	6
How To Set The Raw TCP Device Communication Parameters.....	6
CONNECTING TO YOUR CONTROLLOGIX PLC.....	8
Overview.....	8
PLC Communication Handshaking.....	8
How To Setup ControlLogix PLC Communications .....	9
Raw TCP Gateway 0 (Virtual Channel 0) .....	9
Raw TCP Gateway 1 (Virtual Channel 1) .....	11
Ladder Logic.....	11
USING THE INTERNAL WEB SERVER.....	12
Overview.....	12
Using The Application Description String .....	12
How To Setup Ethernet Communications .....	12
APPENDIX A.....	14
Diagnostics Page .....	14
APPENDIX A.....	15
RAW TCP LoopBack Mode.....	15

## FIGURES

Figure 1 - System Configuration.....	5
Figure 2 - Virtual Communication Channels.....	6
Figure 3 - Example Tag Message Data .....	9
Figure 4 – Use of Logix Tags and Channels .....	11
Figure 5 - Web Server Main Page.....	13
Figure 6 - Sample Diagnostics Page .....	14

# INTRODUCTION

## Product Overview

The 490NBA RAW TCP ControlLogix Ethernet Gateway is designed to move data from a RAW TCP device to and from Rockwell Automation ControlLogix and CompactLogix Programmable Controllers.

A Raw TCP device is a device that sends information as the message contents of a TCP (Transport Control Protocol) packet. This data is specific to the device and can contain binary data, ASCII data or any other data. For example, a TCP barcode device may send ASCII barcode data, a TCP scale may send one or more binary weights or a TCP-enabled pump might send floating point data to indicate a data flow rate. The receiving device for this kind must be able to open the TCP packet and interpret the data. EtherNet/IP Clients like ControlLogix PLCs are unable to receive and interpret this kind of data.

The 490NBA fulfills this role. It can simultaneously transfer data between a Logix Controller and up to six RAW TCP devices over two virtual communication paths. Each communication path is assigned two tags in the Logix controller. There is one tag for receiving data from RAW TCP devices and one tag for sending data to RAW TCP devices.

Only a single rung of ladder logic is required to support each data transfer as the 490NBA works independently of the PLC processor. It automatically access the PLCs data table to store Raw TCP data in the receive tag and get data from the send tag.

Unit configuration is performed using the internal web server. TCP Gateway parameters, ControlLogix data tags and message delimiters are independently specified for each channel.

If you need help with IP addressing, you can download an application at <http://www.rtaautomation.com/support/downloads/IPSetup.exe> to display the currently assigned addresses and set your own values.

Note: This manual uses ControlLogix to refer to both ControlLogix and CompactLogix controllers.

## Specifications

Programmable Controllers Supported:	Rockwell Automation ControlLogix and CompactLogix
Raw TCP Ports	User Definable
Max Message Size	400 Characters
Communications	Bidirectional
Max Number TCP Devices	Six
Virtual Channels	Two Virtual Communication Channels
ControlLogix Tags	Four Tags Total; one send, one receive per communications channel
Supported Tag Type	Strings (Default 82 bytes) Array of sints
Tag Format	sint[0] – Length LSB (Least Significant Byte) sint[1] – Length MSB (Most Significant Byte) sint[2 – n] – Raw TCP Data
IP Addressing	Fixed via Web Server
Power Requirements:	12 VDC 500ma
Temperature Range:	0-70 Degrees C
Dimensions:	4.2” x 3”

## Contents of this Manual

This manual provides detailed instructions on the 490NBA Raw TCP ControlLogix Gateway.

This manual does not describe the Rockwell Automation ControlLogix or CompactLogix controllers, serial communications, RS232 or RS485, or how to troubleshoot an Ethernet network.

## CONNECTING TO YOUR RAW TCP DEVICE(S)

### Overview

The Dual RAW TCP ControlLogix Gateway has two independent channels to send and/or receive simultaneous RAW TCP data from up to six devices as shown in Figure 1.

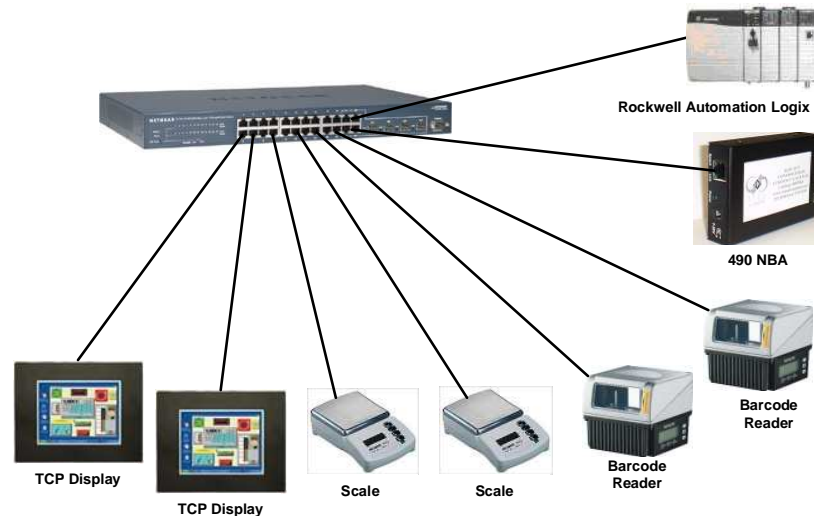

Figure 1 - System Configuration

The six TCP devices can be allocated to either of the two TCP channels. A channel can be assigned a single TCP device or all six TCP devices.

Devices that expect to share data sent from a ControlLogix PLC will typically be assigned to the same channel. When data is transferred from a ControlLogix to raw TCP devices all devices on the same channel receive the identical data. If different output data must be sent to different output devices, each of the devices must be assigned to separate output channels.

Devices that send data to a ControlLogix PLC can be assigned to the same channel or separate channels. When input data is sent to a PLC, it is sent immediately on arrival and it doesn't matter if there are other devices using that channel.

Figure 2 is an example of a configuration in which two output devices and two input devices are assigned to the first channel and two output devices are assigned to the second channel.

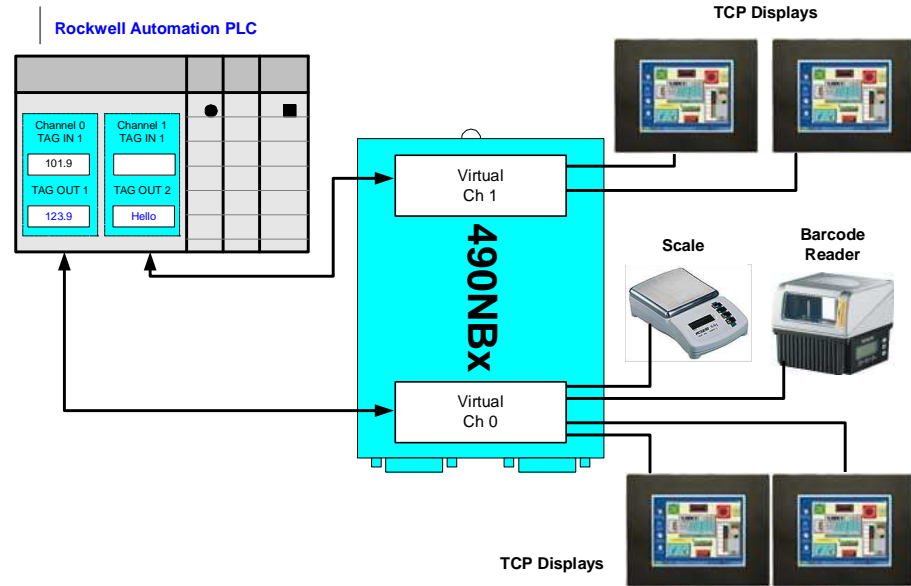

**Figure 2 - Virtual Communication Channels**

Devices are organized into channels using Port Numbers. Port Numbers are application identifiers that uniquely identify an application within a TCP device. For example, in Windows there is a port number that specifies browser data, another one for email and others for things like server access.

In 490NBA applications, the port numbers of your raw TCP devices are used to assign devices to virtual data channels. Each virtual channel is assigned a unique port number using the web server. Devices with that port number use the assigned channel.

## Your TCP Device Requirements

To use a device that sends or receives data over Ethernet with the 490NBA, your device must have a TCP/IP address on the local subnet and it must have a readily identifiable port number.

## How To Set The Raw TCP Device Communication Parameters

There are two communication parameters that must be set in the web server to configure a channel for operation with a 490NBA. These two parameters follow.

### TCP IP Address

The TCP IP Address is the IP Address of a specific device on the local subnet. When this address is set to a non-zero value the 490NBA module will connect to the device and initialize a TCP Connection.

If the TCP/IP Address is set to zero, the 490NBA enters a “Listen Only” mode. In Listen-Only mode, the 490NBA “listens” for connections and

accepts connections with up to six devices that want to exchange data with a ControlLogix controller.

## **TCP Port**

The TCP Port is the port number on which the Gateway will be listening for TCP connections. It is also the port number used to make connections when a specific IP Address is programmed into the web server. This value must be unique for the two Gateway channels.

All devices with the port number of the first channel, transfer data over the first virtual channel. Devices with the port number specified for the second channel transfer data over the second virtual channel.

# CONNECTING TO YOUR CONTROLLOGIX PLC

## Overview

The 490NBA does not use traditional EtherNet/IP server communications. Instead, when a TCP message arrives from your device the data portion of the TCP message is immediately transferred to a tag in the ControlLogix PLC.

Your raw TCP device can send and receive messages over two virtual channels in the 490NBA. Each channel is assigned two tags in the ControlLogix PLC; one tag for sending data and one tag for receiving data on that channel. Each tag is an array of “sints” in the ControlLogix PLC. The number of sints is the maximum number of bytes transferred on that channel plus two. The two additional bytes are handshaking bytes.

## PLC Communication Handshaking

The first two bytes of the sint tag array in the PLC are the handshaking bytes. For incoming messages these bytes contain the number of bytes received from your raw TCP device in the PLC. On outgoing messages these bytes contain the number of bytes to send from the PLC to your raw TCP device.

On incoming messages, the 490NBA sets sint[0] of the incoming tag to the LSB (least significant byte) of the message size and sint[1] of the incoming tag to the MSB (most significant byte) of the message size. After the message is processed by the PLC, the PLC must set both these bytes to zero. A zero length indicates to the 490NBA that the previous message is processed and that the PLC is ready for the next message.

The data length of the incoming Tag must be set to zero by the Programmable Controller prior to initiating communications with a RAW TCP device. Strings (default 82 bytes). String length will change to a non zero. Copy or move your data out of the tag, reset the string length to zero. (tag\_name.LEN)

On outgoing messages, sint[0] and sint[1] also contain the LSB and MSB of the message length. To initiate a transfer to the raw TCP device, the PLC sets the message to transfer in sint[2] through sint[n] of the outgoing tag and then sets sint[0] and sint[1] to the length of the message to send. Immediately on seeing the message length in sint[0] and sint[1] change to a nonzero value, the 490NBA extracts the message, sends it to your raw TCP device and sets sint[0] and sint[1] back to zero. Once sint[0] and sint[1] are set to zero, the PLC can store the next outgoing message.

An example of a sint tag array is shown in Figure 3.

For strings, copy or move your data into the tag, this will change the .LEN to the number of bytes you put into the tag. The 435 will see a non zero in the .LEN, it will then send out your data and will reset the .LEN to zero so you know we processed the data transfer.

TAG INDEX	VALUE	DESCRIPTION
sint[0]	5	Length LSB - 5 Characters to Send
sint[1]	0	Length MSB
sint[2]	'H'	First Message Byte
sint[3]	'E'	Second Message Byte
sint[4]	'L'	Third Message Byte
sint[5]	'L'	Fourth Message Byte
sint[6]	'O'	Five Message Byte

Figure 3 - Example Tag Message Data

## How To Setup ControlLogix PLC Communications

The ControlLogix PLC Communication Parameters are set using the internal web server. There are only two required configuration parameters; the ControlLogix IP Address and the ControlLogix Slot Number.

How to identify the Tags used in the ControlLogix PLC is not described in this section. The next section, the description of the communication channels, describes how to identify the ControlLogix PLC tags.

### ControlLogix IP Address

The ControlLogix IP Address is the TCP/IP address of the ControlLogix Programmable Controller. The TCP/IP Address is retained in non-volatile memory across power cycles.

The Dual RAW TCP ControlLogix Gateway is shipped with the ControlLogix IP Address set to 0.0.0.0.

### ControlLogix IP Slot Number

The Slot Number of the EtherNet/IP Controller in the ControlLogix PLC.

### Raw TCP Gateway 0 (Virtual Channel 0)

Raw TCP Gateway 0 communication parameters are the communication parameters that control the first virtual communication channel. Virtual Channel 0 configuration is composed of the parameters that control incoming messages and the parameters that control outgoing messaging.

### (Raw TCP to ControlLogix) – ControlLogix Tag Name

The ControlLogix Tag Name is the Tag in the ControlLogix PLC that receives the incoming message from the 490NBA. This tag is an array of sints and **must be set to two bytes more than the maximum message data that can be received from a raw TCP device.**

**If using strings, the default is 82 bytes.**

### **(Raw TCP to ControlLogix) - ControlLogix Tag Size minus 2**

The buffer transmit length is the maximum number of characters that can be transferred to a ControlLogix controller in a single message. **The parameter must be set to two bytes less than the number of sints in the incoming ControlLogix tag.**

Note: setting this parameter to zero disables incoming messages on this channel and puts the Gateway in a TCP “connect to” mode.

### **(ControlLogix to Raw TCP) – ControlLogix Tag Name**

The ControlLogix Tag Name is the Tag in the ControlLogix PLC that contains the outgoing message. Data in this tag is transferred from the ControlLogix PLC to your raw TCP device through the 490NBA. This tag is an array of sints and **must be set to two bytes more than the maximum message data that will be sent to a raw TCP device.** **If using strings, the default length is 82 bytes.**

Note: setting this parameter to zero disables outgoing messages on this channel.

### **(ControlLogix to Raw TCP) - ControlLogix Tag Size minus 2**

The buffer transmit length is the maximum number of outgoing characters that will be transferred from a ControlLogix controller to a raw TCP device in a single message. **The parameter must be set to two bytes less than the number of sints in the outgoing ControlLogix tag.** **If using strings, the default length is 82 bytes.**

### **(ControlLogix to Raw TCP) – Poll Time**

The Poll Time Period indicates how often the 490NBA checks the ControlLogix Gateway for outgoing messages. This value is application dependent. Setting it too slow and there will be unnecessary delay before messages are transmitted to the RAW TCP device. Setting the value too fast and the gateway may consume too much Ethernet bandwidth and PLC processing cycles.

The Poll Time Period can be set from zero to 30,000 milliseconds (thirty seconds). Setting it to zero consumes maximum Ethernet bandwidth. The default value is 10 seconds.

The Poll Time period is independently set for each channel.

### **(ControlLogix to Raw TCP) – Start Delimiter**

The one or two character Start Delimiter is inserted prior to the beginning of the data received from the ControlLogix controller. The Start Delimiter is independently enabled for each channel.

Setting the Start Delimiter count to zero disables the Start Delimiter.

### (ControlLogix to Raw TCP) – End Delimiter

A one or two character End Delimiter is appended to the end of the data received from the ControlLogix controller.

Setting the End Delimiter count to zero disables the End Delimiter.

### Raw TCP Gateway 1 (Virtual Channel 1)

Raw TCP Gateway 1 contains the communication parameters for the second virtual channel. These parameters are identical to the first virtual channel parameters described above.

### Ladder Logic

Almost no ladder logic is required to send and receive raw TCP data. For incoming messages, all that is required is logic to detect incoming data (sint[0] and sint[1] set to nonzero), process it and reset sint[0] and [1] to zero. For outgoing messages, all that is required is to store the send data in the outgoing tag beginning at sint[2]. Once the data is stored, sint[0] and [1] of the outgoing message can be set to the number of bytes to send.

Figure 4 illustrates the requirements of the 490NBA Ladder logic.

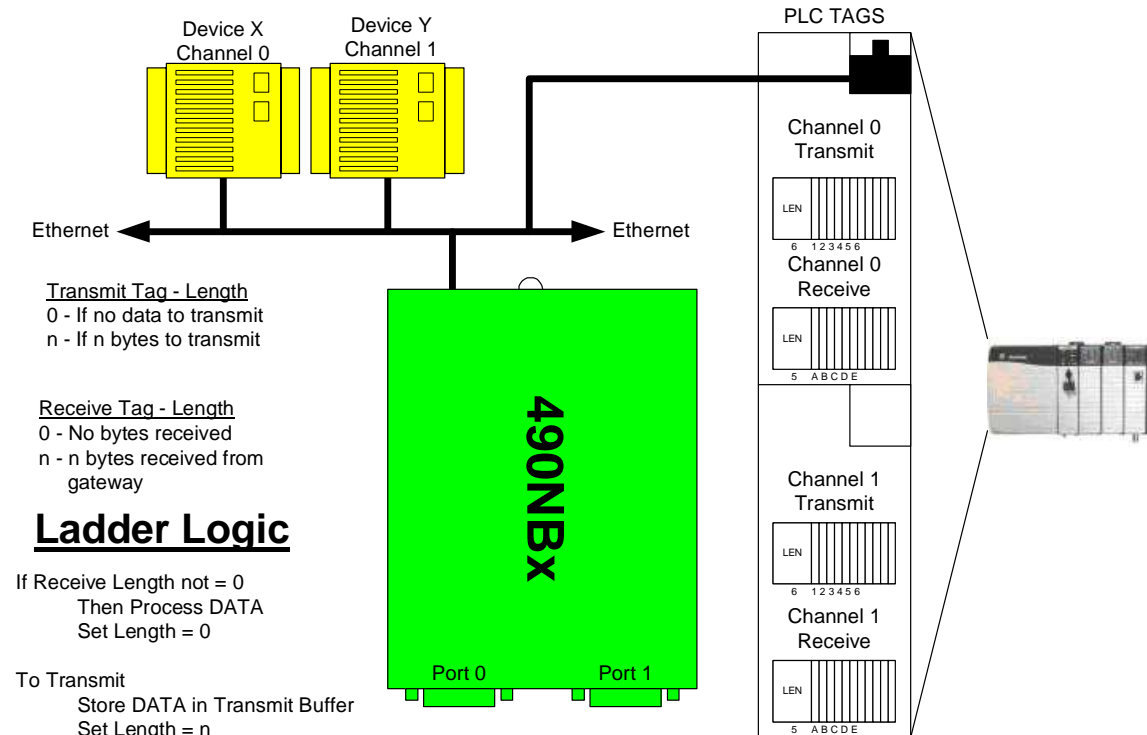

Figure 4 – Use of Logix Tags and Channels

## USING THE INTERNAL WEB SERVER

### Overview

All 490NBA parameters are accessed using the internal web server and any standard browser. Figure 5 shows the main web page of the web interface.

A selected block of configuration data can be revised by clicking the edit button for that block as shown in Figure 5. Each block of the web server corresponds to a section discussed above.

There are three configuration parameters that are specific to 490NBA Module operation. These parameters are defined in this section and set with the internal 490NBA web server.

### Using The Application Description String

The Description block contains a text string that identifies the application to the user. The text string is not transmitted to the ControlLogix Programmable Controller.

### How To Setup Ethernet Communications

#### IP Address

The TC/IP Address is the address of the 490NBA module. This address normally exists on the same subnet as the ControlLogix PLC.

#### Subnet Mask

The Subnet Mask is the address mask for the current subnet.

#### Default Gateway

The Default Gateway is the address of the device which serves as the gateway for non-local TCP/IP addresses. The default gateway TCP/IP address is usually the address of a router.

#### Default Settings

Default settings for these entries are:  
IP Address: 192.168.0.100  
Subnet Mask: 255.255.255.0  
Default Gateway Address: 192.168.0.1



RTA  
ControlLogix®  
Raw TCP Messenger

[Diagnostics Page](#)

**Description**  
RTA ControlLogix Messenger: Enter a description.

**ControlLogix communication is enabled**  
ControlLogix IP address = 192.100.100.25  
ControlLogix slot number = 0

**Raw TCP Gateway 0 is enabled**  
IP Address = 192.100.100.22  
Port = 50200

**Raw TCP to ControlLogix**  
Buffer transmit length = 20  
ControlLogix tag name is  
TagEchoW1

**ControlLogix to Raw TCP**  
Buffer transmit length = 12  
Poll Time = 2000  
ControlLogix tag name is  
XTAG1  
End delimiter byte1 = [CR] 13 0x0D  
End delimiter byte2 = [LF] 10 0x0A

**Raw TCP Gateway 1 is disabled**

[Edit](#)

**Network Settings**  
IP address: 192.100.100.166  
Subnet mask: 255.255.255.0  
Default gateway: 192.168.0.1

[Edit](#)

MAC address: 00-03-F4-01-5E-6A  
Revision: 1.02

Figure 5 - Web Server Main Page

## APPENDIX A

### Diagnostics Page

A Diagnostics page is accessible from the main page of the internal web server. The Diagnostics page illustrates the connection status to the ControlLogix PLC, the connection status of the Raw TCP device and the status of connections to the Tags in the ControlLogix PLC data table.

Figure 6 illustrates the diagnostics page with all normal connections.

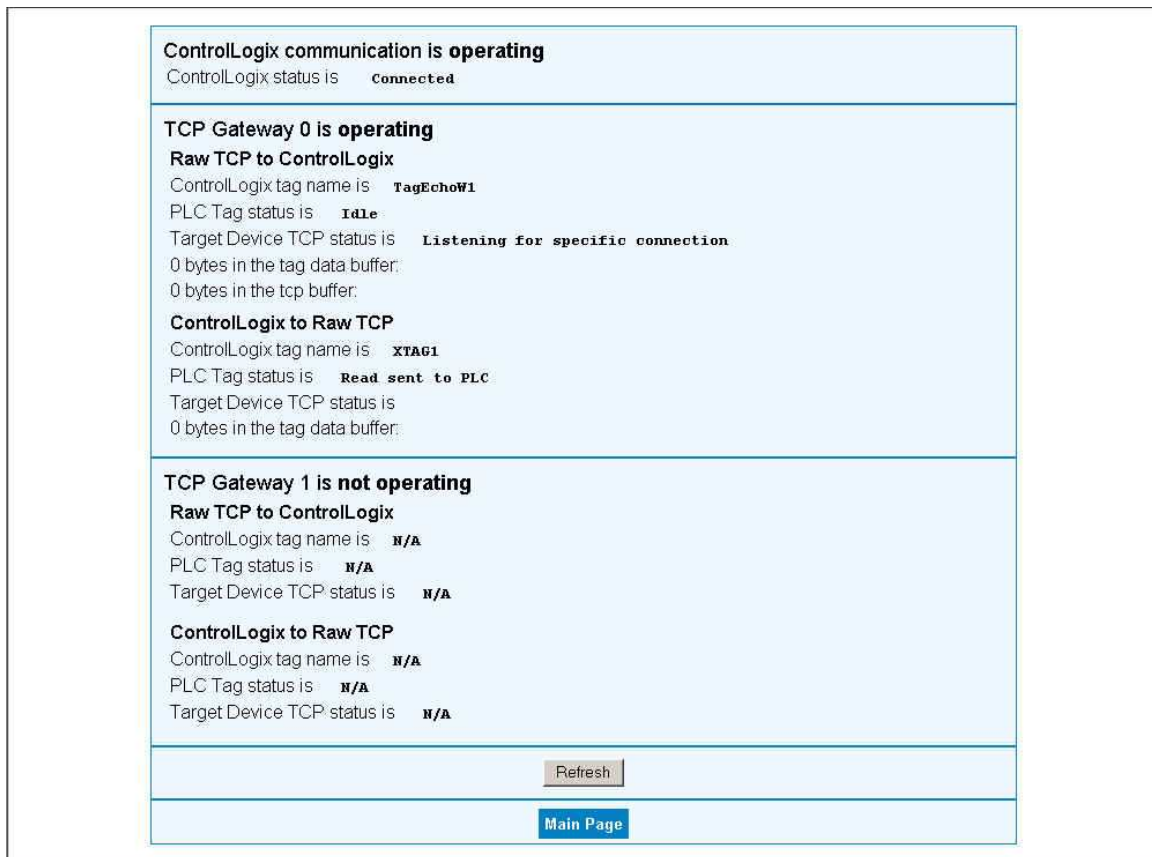

Figure 6 - Sample Diagnostics Page

Note that you may have to refresh your browser to view the most recent communication status.

Set the 490NBA Application Note for details on the error messages that can be displayed on this page.

## APPENDIX A

### RAW TCP LoopBack Mode

This mode allows the user to test the RAW TCP to Logix setup before connecting the ControlLogix to the Dual RAW TCP Gateway. If the Gateway has the ControlLogix IP Address set to 0.0.0.0 LoopBack mode is enabled (and all communication with the ControlLogix is disabled).

Example:

ControlLogix IP Address: **0.0.0.0**

Enable Raw TCP Gateway 0: **checked**

RAW TCP to ControlLogix

TCP IP Address: **0.0.0.0**

TCP Port: **50200**

ControlLogix Tag Size minus 2: **10**

Test:

Connect to Raw TCP Gateway 0 with TCP Test Tool or a similar TCP test program.

Send **A12345Z**

Results echoed back to the TCP connection: **A12345Z**

The internal data buffers can be viewed on the Diagnostics page found on the main menu.