

ASCII to EtherNet/IP

Gateway

Get AMS Displays on EIP!



Seamlessly Transfer Data
Between Your ASCII Devices And
Rockwell PLCs Using EtherNet/IP™

Fast, No Risk, ASCII to PLC Solution

ADAPTIVE
Adaptive Micro Systems Inc

NO PLC MESSAGE INSTRUCTIONS!

**Simultaneous Dual Port ASCII Operation With Support For Logix,
PLC5, SLC5/05**

Only One Rung Of Simple Ladder Logic required

◆ Barcode Readers ◆ Weigh Scales ◆ Glue Machines ◆ Label Machines ◆ RF ID Devices ◆
Temperature Controllers ◆ HMIs ◆ Displays ◆ ASCII Keypads ◆ All Other Serial Devices

Some Important Questions You May Be Asking Yourself:

1. Why can't I find a better way to move ASCII data to Rockwell Automation Logix Processors than Serial Tunneling?
2. How can I get away from the latency problems associated with all other ASCII gateways?
3. Where can I get a device that is designed for the kinds of devices that I use on a daily basis?

If you need to move serial data to Logix Programmable Controllers you now have an exceptional tool – a tool designed for this task and this task only. With simultaneous, bi-directional operation on two serial ports, you can double your efficiency at half the investment. Using unique Ethernet communications technology your data is transferred automatically without PLC intervention, not during some artificial network scan. And best of all, the EtherNet/IP Messenger operates in your world, using your programmable controller tags as the source and destination for your ASCII data.

FEATURES

- *True Gateway – Serial Tunneling **IS NOT** Supported by This Device*
- *Unique, Lightning Fast Technology For Reading/Writing ASCII Data Between Logix Tags And Your Serial Devices*
- *Lowest Latency Response of any Rockwell PLC Gateway – In Fact Since Data Moves Automatically and Instantly It Can't Get Lower!*
- *Transfer Data Independently to and from Either Serial Port*
- *Separate Logix Read and Write Tags for Each Serial Port*
- *Only One Rung of PLC Ladder Logic Required – No Message Instructions*
- *Simple, Browser-Based Configuration*
- *Specially Designed for ASCII/Logix Communications – Custom Versions available on Request*
- *Use RS232 or RS485*

SPECIFICATIONS

	Ethernet Hardware		LED's		Physical
	32-Bit Motorola Coldfire		Link/Speed LEDES		Dimensions: 4.2" x 3"
	10/100 BaseT		Data LED		Weight: 5oz
	RJ45 connector				
			Power Requirements		Environmental
	Serial Communications		12VDC @ 500ma		0 – 70 Degrees C
	Two DB-9M Connectors		9-30VDC		5 to 90% Relative Humidity
	Baud Rate: 300 to 19.2K				
	Even/Odd/No/Space Parity		Network Interface		Mounting Options
	One RS232 Serial Port		Ethernet TCP/IP		Desk Top
	One RS232/485 Port				Din Rail
			Configuration		Panel
			Browser Interface		

DIMENSIONS

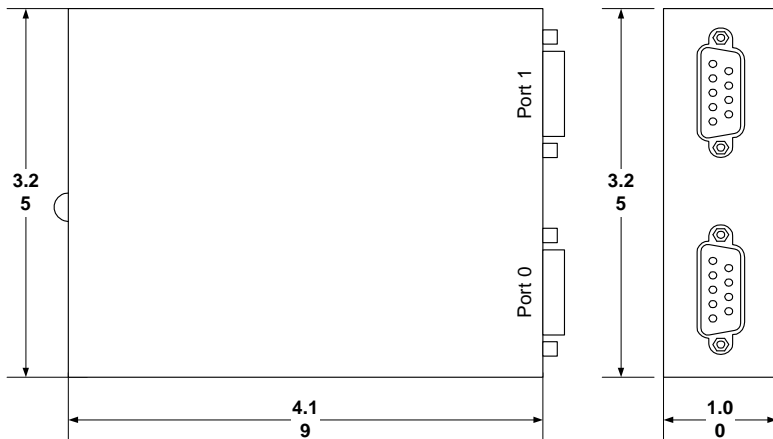

Note: All dimension are in inches

SERIAL PORT PINOUTS

Serial Port 0 or 1 (RS232 MODE)

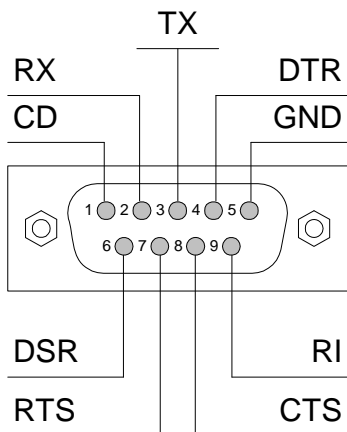

Serial Port 0 (RS485 MODE)

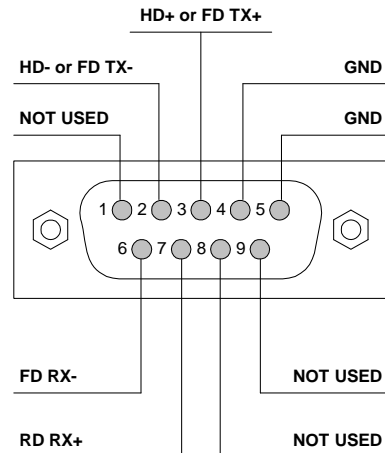

ORDERING INFORMATION

435NBA	Logix ¹ Dual Port EtherNet/IP Gateway	Desk Mounted Gateway
435NBA-P	Logix Dual Port EtherNet/IP Gateway	Panel Mounted Gateway
435NBA-D	Logix Dual Port EtherNet/IP Gateway	Din Rail Mounted Gateway
435NBP	PLC5 Dual Port EtherNet/IP Gateway	Desk Mounted Gateway
435NBP-P	PLC5 Dual Port EtherNet/IP Gateway	Panel Mounted Gateway
435NBP-D	PLC5 Dual Port EtherNet/IP Gateway	Din Rail Mounted Gateway
435NBS	SLC5/05, MicroLogix Dual Port EtherNet/IP Gateway	Desk Mounted Gateway
435NBS-P	SLC5/05, MicroLogix Dual Port EtherNet/IP Gateway	Panel Mounted Gateway
435NBS-D	SLC5/05, MicroLogix Dual Port EtherNet/IP Gateway	Din Rail Mounted Gateway

PRICING AND AVAILABILITY INFORMATION

Rick DeMorrow
REAL TIME AUTOMATION
2825 N. MAYFAIR RD. SUITE 11
WAUWATOSA WI 53222
sales@rtaautomation.com
414-453-5100 (V)
414-453-5125 (F)

Ordering Information

U.S. customers may by e-mail (orders@rtaautomation.com), by fax (414-453-5125), or by telephone with a Customer Service Representative from 7:30 AM - 5:30 PM (CST).

Information to Provide With Your Order

1. Your name, telephone number, and e-mail address;
2. Purchase order number;
3. Name, telephone number, and e-mail address of the person using the product;
4. Shipping address;
5. Billing address; and,
6. Catalog number, name, size, and quantity of each item ordered

Use MasterCard, VISA, American Express or PayPal

You can order RTA's products using MasterCard, VISA, American Express or PayPal. Email your order and specify that you wish to pay electronically. Our sales team will email you an invoice with a direct link to PayPal where you can use any number of options for payment.

RTA U.S. Sales Representatives

¹ Logix refers to both ControlLogix and CompactLogix

For additional assistance, please feel free to contact the distributor in your area.

Free Shipping for Qualified Orders

All products are shipped F.O.B. Milwaukee, Wisconsin. Shipping charges will be prepaid and added to the invoice. Please inquire about costs for non-standard shipments or carriers.

Same Day Shipping and Next Day Delivery

Orders received by 1:00 p.m. CST Monday through Thursday will be shipped the same day by overnight air express if requested. Otherwise orders are shipped in 48 hours.

Quality Guaranteed

We stand behind our products. If you're not satisfied that our products are of the highest quality available, we will refund your money.

Pricing and Terms

Prices are subject to change without notice. Please confirm current pricing at the time of your order. Payment must be in U.S. dollars. Terms are net 30 days. Thereafter, a carrying charge of 1.5% per month will be added to the unpaid balance.